

**AGC™**  
HEAT TRANSFER

# 300-F

PLATE HEAT EXCHANGER FRAME

*"Building the best, servicing the rest"™*

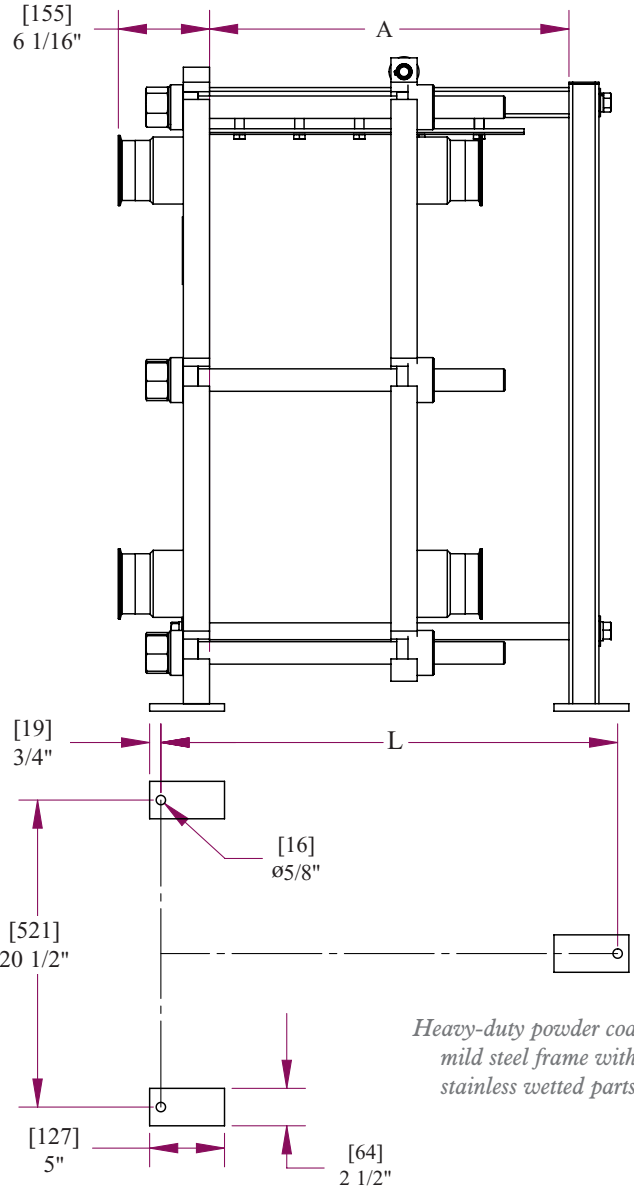
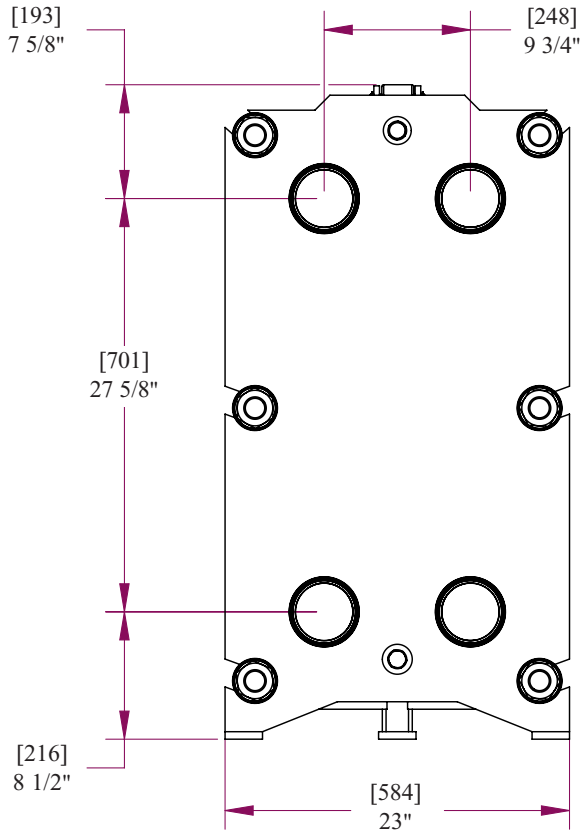

*Heavy-duty powder coated mild steel frame with stainless wetted parts*

*This drawing is the confidential property of AGC HEAT TRANSFER and it must not be reproduced in any form without written consent*

FRAME SIZE	FOOT CENTERS [L]	RAIL LENGTH [A]	PLATE CAPACITY
1	30 <sup>1</sup> / <sub>2</sub> " [775]	24" [610]	100
2	42 <sup>1</sup> / <sub>2</sub> " [1079]	36" [914]	180
3	54 <sup>1</sup> / <sub>2</sub> " [1384]	48" [1219]	260

*Dimensions not to be used for construction*

### GENERAL INFORMATION

Plate and Gasket Weight:	4.0 lbs / 1.8kg
Plate Capacity:	0.26 US Gallons / .98 L
Heat Transfer Area:	3.2 ft <sup>2</sup> / .30 m <sup>2</sup>
Plate Thickness:	0.6mm
Frame Weight: (according to size)	1000 - 1100 lbs / 454 - 499 kg
Standard Frame Connections:	4" Sanitary Clamp



**Western**  
9109 SE 64th Ave.  
Portland, OR 97206  
503.774.7342  
800.715.8820  
FAX 503.774.2550

**Central**  
1325 Remington Rd.  
Suite T  
Schaumburg, IL 60173  
847.301.6890  
FAX 503.774.2550

**Eastern**  
10129 Piper Lane  
Bristow, VA 20136  
703.257.1660  
800.825.8820  
FAX 703.330.7940



AMERICAN MADE

**proflow** sanitary  
S E R I E S

See us on the web at [www.AGCHeatTransfer.com](http://www.AGCHeatTransfer.com)

300-F 10-11